

FLOAT AND THERMOSTATIC STEAM TRAPS

FLT32 (Cast steel DN40-50)

DESCRIPTION

FLT32 float and thermostatic (integral air vent) steam traps series are designed for all types of low and high pressure steam heating and process equipment.

Typical applications include unit heaters, heat exchangers, driers, jacketed vessels and all the applications where continuous drainage is essential.

Connections are female screwed or flanged for horizontal or vertical installation.

MAIN FEATURES

Modulating discharge.

Discharges condensate at steam temperature.

Unaffected by sudden or wide load and pressure changes.

Excellent air discharge (by thermostatic air vent).

OPTIONS: SLR – steam lock release
Equalizing plug or vent connection

USE: Saturated and superheated steam.

AVAILABLE

MODELS: FLT32-4,5 , 10 , 14 and 21

SIZES: DN11/2" - DN2" ; DN40 – DN50

CONNECTIONS: Female screwed ISO7/1 Rp (BS21)
Flanged EN 1092-1 PN40 or ANSI

INSTALLATION: Standard horizontal installation –
From right to left FLT32 (R-L)

Upon request:

-horizontal installation with the flow from left to right (L-R)

-vertical installation with the flow from top to bottom (V)

MAX. DIFFERENTIAL PRESSURE

FLT32-4,5 : 4,5 bar

FLT32-10 : 10 bar

FLT32-14: 14 bar

FLT32-21: 21 bar

CE MARKING (PED - European Directive 97/23/EC)	
PN 40	Category
DN40 - DN50	1 (CE Marked)



BODY LIMITING CONDITIONS		
FLANGED PN40 / ANSI 300*	FLANGED ANSI 150 **	RELATED TEMP.
ALLOW. PRES.	ALLOW. PRES.	
37,1 bar	15,4 bar	100 °C
33,3 bar	13,8 bar	200 °C
30,4 bar	12,1 bar	250 °C
27,6 bar	10,2 bar	300 °C

PMO - Max. operating pressure 32 bar

TMO - Max. operating temperature 250 °C

* According to EN1092-1:2007 ; ** Acc. to EN1759-1:2004

Body limiting conditions PN40 or below, depending on the type of connection adopted. Rating PN40 for thread, SW and BW.

FLOW RATE CAPACITY IN Kgs/h												
MODEL	SIZE	DIFFERENTIAL PRESSURE (bar)										
		0,5	1	1,5	2	4,5	7	10	12	14	16	21
FLT32-4,5	40-50	2400	3400	3900	4500	7300						
FLT32-10	40-50	1500	2000	2600	3000	4000	5400	6200				
FLT32-14	40-50	950	1300	1600	1800	2600	3250	3900	4210	4950		
FLT32-21	40-50	950	1300	1600	1800	2600	3250	3900	4210	4950	5000	5600

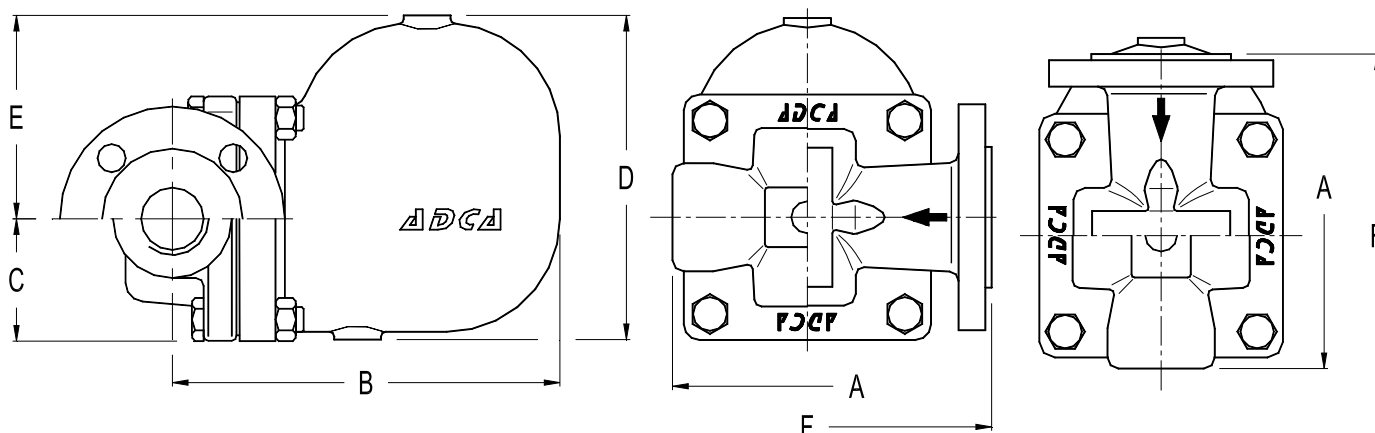
Vertical Installation (V)

DIMENSIONS (mm)																
Screwed							EN PN16 / 40			ANSI 150			ANSI 300			
SIZE DN	A	B	C	D	E	WGT. Kgs	F	B	WGT. Kgs	F	B	WGT. Kgs	F	B	WGT. Kgs	
40-11/2"	210	248	79	208	131	16,9	230	248	20,3	230	248	19,1	230	248	22,1	
50-2"	210	248	79	208	131	17,5	230	248	20,7	230	248	20,5	230	248	22,3	

MATERIALS		
POS.Nr.	DESIGNATION	MATERIAL
1	Body	GP240GH / 1.0619
2	Cover	GP240GH / 1.0619
3	*Gasket	Stainless st. / Graphite
4	*Seat	CF8 / 1.4308
5	*Valve	AISI 420 / 1.4021
6	*Lever	AISI 304 / 1.4301
7	*Float	AISI 304 / 1.4301
8	*Air vent	Stainless st. (Bimetallic)
9	Bolts	Steel 8.8

*Available spare parts.

